



SERIES 30M

MULTI-PORT FLANGED 3 & 4 WAY BALL VALVES FULL PORT L,T, OR LL BALL

MANUAL OR AUTOMATED 2"-6" (DN50-DN150)

FEATURES

- Four ball seats
- Simplicity in replacing valve seats and packing
- Investment cast body DN50(2") to DN100(4")
- Sand casting DN150 (6")
- Standard L-port and T-port; optional LL port for 4 way
- Tightness to ISO 5208 Cat. A
- Patented "Sealmaster" stem arrangement
- Double stem sealing complies with TA-LUFT requirements
- Semi-Trunnion Mounted
- Lower operation torque
- ISO 5211 mounting plate
- Full bore and flanged connection
- Anti-static design
- Optional ball & body patterns for various flow paths
- Valve pressure rating:

ANSI Class 150/300
DIN PN 10/16/25/40
JIS 10K

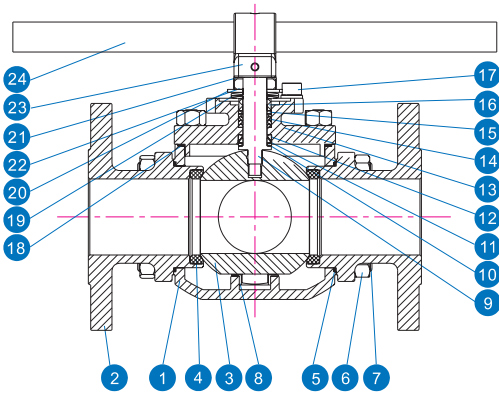

MATERIAL LIST

NO.	PART NAME	MATERIAL	Q'TY
1	Body	CF8M / WCB, 1.4408 / 1.0619	1
2	Cap	CF8M / WCB, 1.4408 / 1.0619	4
3	Ball	ASTM A351 Gr. CF8M	1
4	Ball Seat	RPTFE	4
5	Body Gasket	PTFE	4
6	Bolt Nut	A2-70	#
7	Bolt	A2-70/8.8	#
8	Bushing	50% S.S Powder / 50% PTFE	1
9	Anti-Static Stem	A276 Type 316	1
10	Lower Thrust Washer	50% S.S Powder / 50% PTFE	1
11	Compress Ring	316SS	1
12	Upper Thrust Washer	TFM1600	1
13	Cover	CF8M / WCB, 1.4408 / 1.0619	1
14	V-Ring Stem Packing	PTFE	1 Set
15	Thrust Washer	50% S.S Powder / 50% PTFE	1
16	Gland	304SS	1
17	Stop Bolt	Stainless Steel	2
18	Cover Seal	PTFE	1
19	Belleville Washer	301SS	2
20	Triangle Stopper	304SS	1
21	Lock Saddle	304SS	2
22	Stem Nut	304SS	1
23	Stem Adapter	304SS	1
24	Handle	SGP Zn Plating	1
25	Block Cover	ASTM A351 Gr. CF8M / ASTM A216 Gr. WCB	1*

PRESSURE/TEMPERATURE CHART

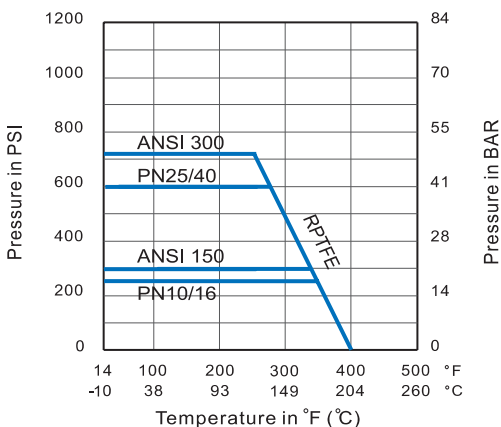

2" - 3" , All Standards: 20pcs

4" , All Standards: 28pcs

6" Class 150, PN10/16, 10K, All Standards: 44pcs

6" Class 300, PN25/40, 20K, All Standards: 56pcs

* For No 25 Block cover, please refer to page 2

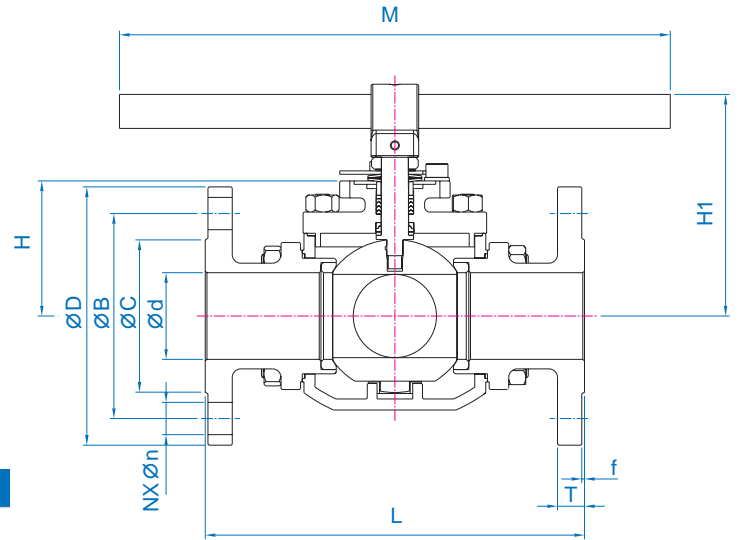
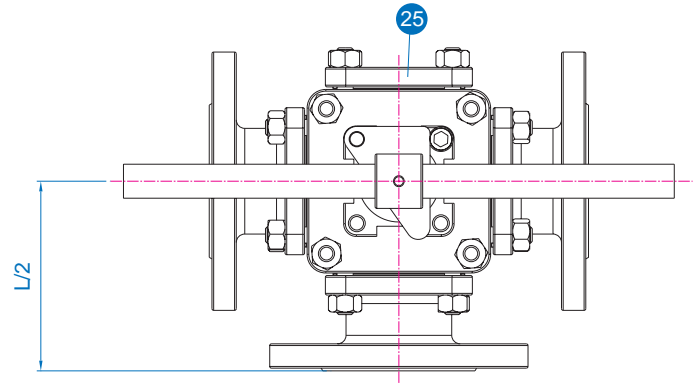
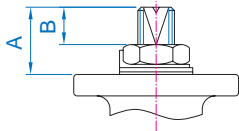
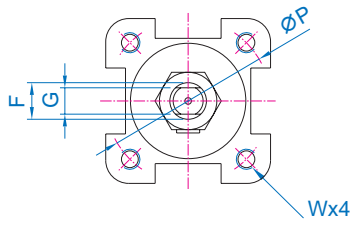

DIMENSIONS (mm)

Size	DN	A	B	ØP	F	G	W
2"	50	27.5	17.5	70	16.0	9.5	M8
2-1/2"	65	43.0	24.0	102	22.3	17.0	M10
3"	80	41.5	24.0	102	22.3	17.0	M10
4"	100	47.2	29.0	102	28.6	17.0	M10
*6"	150	65.0	37.0	125	34.0	23.0	M12
**8"	200	65.0	37.0	125	34.0	23.0	M12

Size	DN	Ød	ØB					ØC					ØD					T				
			ANSI 150	ANSI 300	JIS 10K	PN 10/16	PN 25/40	ANSI 150/300	JIS 10K	PN 10/16	PN 25/40	ANSI 150	ANSI 300	JIS 10K	PN 10/16	PN 25/40	ANSI 150	ANSI 300	JIS 10K	PN 10/16	PN 25/40	
2"	50	50	120.5	127.0	120	125	125	92.0	96	102	102	152.0	165.0	155	165	165	15.9	22.3	16	20	20	
2-1/2"	65	65	139.5	149.0	140	145	145	105.0	116	122	122	178.0	190.0	175	185	185	17.5	25.4	18	18	22	
3"	80	76	152.5	168.0	150	160	160	127.0	126	138	138	190.0	210.0	185	200	200	19.1	28.6	18	20	24	
4"	100	100	190.5	200.0	175	180	190	157.0	151	158	162	229.0	254.0	210	220	235	23.9	31.8	18	20	24	
6"	150	150	241.3	269.9	240	240	250	216.0	212	212	218	279.4	317.5	280	285	300	25.4	36.6	22	22	28	
**8"	200	150	298.4	N/A	N/A	295	N/A	269.9	N/A	268	N/A	343.0	N/A	N/A	340	N/A	28.6	N/A	N/A	24	N/A	

Size	DN	f				N					Øn					L					H	H1	M
		ANSI 150/300	JIS 10K	PN 10/16	PN 25/40	ANSI 150	ANSI 300	JIS 10K	PN 10/16	PN 25/40	ANSI 150	ANSI 300	JIS 10K	PN 10/16	PN 25/40	ANSI 150	ANSI 300	JIS 10K	PN 10/16	PN 25/40			
2"	50	1.6	2	3	4	8	4	4	4	19.0	19.0	19	18	18	220	220	220	230	230	80.0	136.5	395	
2-1/2"	65	1.6	2	3	4	8	4	4	8	19.0	22.0	19	18	18	280	280	280	290	290	97.0	162.0	495	
3"	80	1.6	2	3	4	8	8	8	8	19.0	22.0	19	18	18	285	285	285	310	310	108.0	186.0	495	
4"	100	1.6	2	3	8	8	8	8	8	19.0	22.0	19	18	22	347	347	347	350	350	129.0	213.0	650	
*6"	150	1.6	2	3	8	12	8	8	8	22.2	22.2	23	22	26	480	540	480	480	540	214.5	280.0	800	
**8"	200	1.6	2	3	8	N/A	12	12	N/A	22.2	N/A	23	22	N/A	480	N/A	480	480	N/A	215.0	280.0	800	

** Reduce bore only
 * For 6" on ANSI 300#, PN25/40, JIS 20K, Please consult factory.

BALL PORT CONFIGURATION

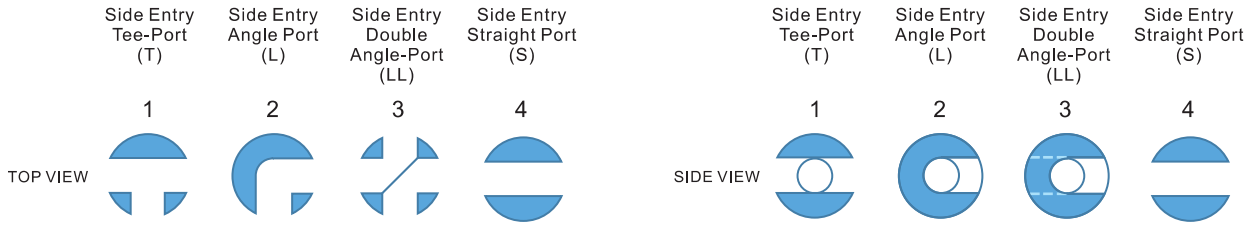

All T-Port Flow Patterns can be changed in the field without disassembling valve

T-PORT 90° TURN

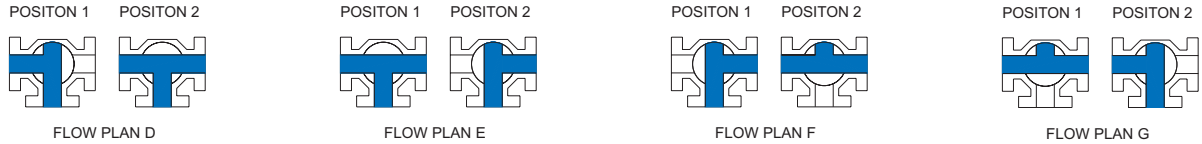

T-PORT 180° TURN



L-PORT 90° TURN

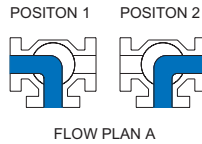

L-PORT 180° TURN

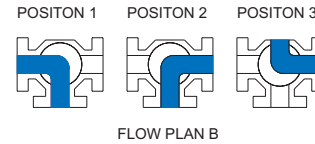

LL-PORT 90° TURN

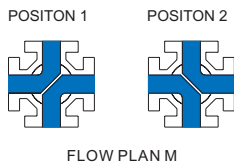

L-PORT 180° TURN

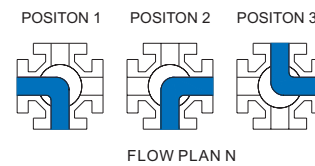

4- WAY VALVES

Optional Plans Available
Using T, L and Standard Ball
Consult Factory

ORDERING INFORMATION

30M MULTIPORT	FLANGE F	FULL PORT 1	SS316 1	RPTFE R	2-1/2" J	PN 10/16 E	T-HANDLE 2	ANGLE PORT(L) 2	3-WAY A						
30M MULTIPORT	END CAP TYPE	PORT TYPE	BODY, CAP /BALL, STEM		SEAT MATERIAL		SIZE	PRESSURE		HANDLE TYPE	BALL PORT CONFIGURATION		BODY PORT CONFIGURATION		
	F FLANGE	1 FULL PORT	1	CF8M/316	R	RPTFE	H 2"	A	ANSI 150	2 T-HANDLE	1	Tee-Port(T)	A	3-way	
	O OTHER		4	WCB/316			J 2-1/2"	B	ANSI 300	3 BARE SHAFT	2	Angle Port(L)	B	4-way	
							K 3"	E	PN 10/16 F1	5	GEAR BOX	3	LL Port(LL)		
							L 4"	H	PN 25/40 F1						
							N 6"	K	JIS 10K						
						L		JIS 20K							

*For reduced port or large size, please consult factory for details.